PDG Commerce

Installation Guide

**PDG Software, Inc.
1751 Montreal Circle, Suite B
Tucker, Georgia 30084-6802**

Copyright ©1998 - 2004 PDG Software, Inc.; All rights reserved.

PDG Software, Inc. ("PDG Software") retains all ownership rights to the software programs (referred to herein as "Software") offered by PDG Software and related documentation. Use of the Software and related documentation is governed by the license agreement accompanying the Software and applicable copyright law.

THIS DOCUMENTATION IS PROVIDED "AS-IS" WITHOUT WARRANTY OF ANY KIND. IN NO EVENT SHALL PDG SOFTWARE BE LIABLE FOR ANY LOSS OF PROFITS, LOSS OF BUSINESS, LOSS OF USE OR DATA, INTERRUPTION OF BUSINESS, OR FOR INDIRECT, SPECIAL, INCIDENTAL, OR CONSEQUENTIAL DAMAGES OF ANY KIND, ARISING FROM ANY ERROR IN THIS DOCUMENTATION.

PDG Software, Inc.
<http://www.pdgsoft.com>

September, 2004

Contents

Chapter 1	Installation Overview	7
	Installation Process	7
	Configuration	7
	Embedding PDG Commerce	8
Chapter 2	Installation Preparation	9
	Preparing for Installation	9
	Installation Notes	10
	System Requirements for PDG Commerce	10
	Downloading PDG Commerce	11
	Preparing to Upgrade from PDG Commerce 1.x.....	11
Chapter 3	Installation	13
	Unzipping the Archive	13
	Web Server Installation	14
	Transferring the 'Your_CGI_Directory' Files	14
	Transfer the 'Your_CGI_Directory' Contents	14
	The 'PDG_Commerce' Directory	15
	Transferring the 'Your_Document_Directory' Files	15
	Adjusting Files	16
	Setting Permissions for 'PDG_Commerce' Subdirectory Contents	17
	Install the PDG Commerce License.....	18
	Local Installation	18
	Database Setup.....	19
	Database Driver Type	19
	DSN	19
	SQL Server	19
	SQL Server Database.....	20
	MS Access database filename.....	20
	Login Name	20
	Password	20
	Setting Up the Database.....	20

Logging In to the Commerce Administrator.....	20	
Chapter 4	Embedding PDG Commerce	21
Chapter 5	PDG Commerce File Structure	23
Chapter 6	Setting Permissions	25
Windows NT Permissions		25
File level permissions		25
Web Server level permissions.....		26
Windows 2000 Permissions.....		28
File level permissions		28
Web Server level permissions.....		29
Unix Permissions		30
File level permissions		30
Server level permissions		30

Installation Overview for PDG Commerce

Adding PDG Commerce to your web site consists of three main activities.

In order, they are:

- Installation
- Configuration
- Embedding PDG Commerce in your web store

Installation Process

The installation process includes:

- Downloading PDG Commerce files
- Uncompressing PDG Commerce files
- Copying PDG Commerce files to your ISP's server
- Adjusting PDG Commerce files to reflect the directory location and structure on the ISP's server
- Setting security permissions for files
- Installing the License
- Setting database connectivity (ODBC or MySQL)
- Installing any HTML design components, for HTML editors such as Macromedia Dreamweaver, Microsoft FrontPage, or NetObjects Fusion Components

Configuration

Configuration consists of using the Merchant Administrator to configure PDG Commerce's many options including the addition and maintenance of products.

Configuration is only touched upon in this guide, in regards to database connectivity. For an indepth explanation of the configuration settings for PDG Commerce, see the **PDG Commerce Users Guide**.

Embedding PDG Commerce

Embedding PDG Commerce consists of adding PDG Commerce functionality to your web store, and modifying PDG Commerce's templates to match your web stores design and layout. This can be done by using HTML forms and hyperlinks to 'call' PDG Commerce functions. You can also use plugin components for PDG Commerce for popular HTML editors, such as Macromedia Dreamweaver and Microsoft Frontpage. For an indepth explanation of the calls to PDG Commerce and the PDG Commerce HTML templates, see the **PDG Commerce Technical Reference**.



Preparing to Install PDG Commerce

Following this guide will make the installation process easy and will have you up and running in no time.

Preparing for Installation

Prior preparation can prevent future headaches, so we recommend that you run through the following checklist before beginning installation:

Make sure you know the platform of the server on which your Web store resides or will reside.

- Verify that your system or your site's host server meets the hardware/software requirements spelled out in the next section.
- Have your user I.D and password handy so that you can access your web store's host server.
- If you are going to install PDG Commerce on your web host's server, have your web host's database connectivity information available. This may include a username and password, and a DSN for ODBC databases.
- If using SSL, know the complete URL to the secure server.
- Finally, this manual assumes that you have a basic understanding of zip/unzip utilities, file transfer protocol (FTP) and Telnet programs, are familiar with CGI and know the location of your cgi directory on your host's server. If you are not, you may want to enlist additional help or familiarize yourself with these programs.

Installation Notes

It cannot be stressed strongly enough, how important it is that your PDG Commerce site have the proper permissions set, not only for security reasons, but also to ensure proper operation. Many errors in functional operation can be traced to having improper permissions on the directories or files, particularly the 'PDG_Commerce' directory.

If you are running on a Windows 2000/NT server, the file permissions for the 'PDG_Commerce' directory (and all files and subdirectories it contains) are "Modify (Read, Write, Execute, Delete)" for the anonymous browser user. It is also extremely important that the web server permissions are set so that anonymous users cannot browse your 'PDG_Commerce' directory. Details on setting permissions are contained in a later chapter of this guide.

Note that PDG Commerce is a server-side program. No client-side version of it exists. To operate properly, it is necessary to have a web server program running on the computer that you want the software to run on, and the pages must be viewed through that server. Simply previewing them in your HTML editor on your local machine is not enough, because certain elements will not work properly.

System Requirements for PDG Commerce

Before installing PDG Commerce, verify that the system which will be running PDG Commerce meets certain requirements.

Generally, the following requirements should be met in order for PDG Commerce to function properly:

- A Web server that is Common Gateway Interface (CGI) compliant. Most major Web servers, including Apache, IIS, Netscape, NCSA, Cern, etc. are compliant. The CGI directory on your web server must be able to execute compiled binary scripts in the web browser.
- At least 2 MB of hard drive space available in the CGI directory
- Ability for the Web server to access and write to the CGI directory and subdirectories for retaining logs and invoice numbers
- For Windows 2003/2000/NT servers, ODBC connectivity and access to an ODBC datasource is required.
- For UNIX machines, mySQL should be installed and you should verify it is operational and running properly.

As for your customers, they will need to use a Web browser that supports client-side cookies and JavaScripts in order for PDG Commerce to display and function properly while visiting your Web store. For the vast majority of your customers today, this will not be an issue as Netscape Communicator and Navigator and Microsoft Internet Explorer are compatible.

Downloading PDG Commerce

If you have everything you need from the checklist and your system, and your host's system meets the requirements, you should be ready to install PDG Commerce. The first step is to download the software, if you have not already done so.

When you download PDG Commerce, you are retrieving what we call an "archive". The archives include the executables and files which comprise PDG Commerce, and the User Guide and Installation manual in Adobe Acrobat format (PDF).

If you have not already done so, go to www.pdgsoft.com and download the PDG Commerce files.

Preparing to Upgrade from PDG Commerce 1.x

If you are upgrading from an older version of PDG Commerce, you will need to clean out all old sessions from the database tables first. This can be found in the "Maintenance" section of the Merchant Administrator. Click on "Purge" to clear out the data. It is important to do this before beginning the upgrade / installation from an older PDG Commerce to PDG Commerce 4.0.



Completing a new installation

This chapter will guide new users of PDG Commerce in the installation of the software. Prior to beginning the steps outlined throughout, you should make sure that you have downloaded the correct version of PDG Commerce.

Unzipping the Archive

If you have not already done so, download PDG Commerce by following the steps outlined in 'Getting Started' at the beginning of this guide. The zip file you downloaded is referred to as an "archive".

Next, extract the archive files using a zip/unzip utility such as WinZIP. Your extracted archive should have the following structure:

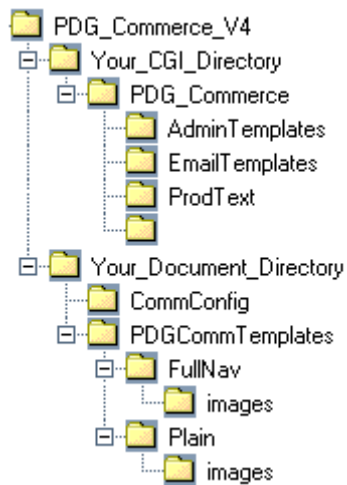

PDG Commerce 4.0 archive structure

Along with the 'Your_CGI_Directory' and 'Your_Document_Directory' subdirectories, there will also be some *.pdf files. The *.pdf files will include the installation guide, the license agreement, and the QuickStart Guide. All of these .pdf files can be viewed using Adobe Acrobat Reader.

Web Server Installation

PDG Commerce requires a web server and database connectivity to run properly. PDG Commerce for Microsoft Windows is distributed ready to work with Microsoft Access, Microsoft SQL Server, or SQL databases. For PDG Commerce for UNIX, you must have access to an operational mySQL database. It is your responsibility to have access to a functioning webserver and database connectivity.

If you are installing PDG Commerce on your host's server, you must obtain from your host the database connectivity information and configure database connectivity accordingly.

For anyone using the Windows version of PDG Commerce and Microsoft Access for their database backend, you must copy the commerce.mdb file from your local PDG_Commerce directory to your site's PDG_Commerce directory, or the location specified by your ISP, and configure database connectivity accordingly. If you are transferring this file via FTP, you should transfer it in binary format.

Transferring the 'Your_CGI_Directory' Files

Using an FTP program (such as WS-FTP) -

1. Start a session and connect to your Web store's location on its host server.
2. In the 'Local System' window of your FTP session, locate the directory containing the PDG Commerce files that you extracted.

Transfer the 'Your_CGI_Directory' Contents

Transfer the contents of the 'Your_CGI_Directory' subdirectory into your Web store's CGI directory (seen in the 'Remote System' window of the FTP session) in the following manner:

NOTE: *You may first need to create a CGI directory if one does not exist.*

1. Transfer the four executable files (CommConfig.exe, Commerce.exe, CommerceLog.exe, and redirect.exe) as "binary" since these are compiled binary objects.
2. Transfer the 'PDG_Commerce' subdirectory and its contents as 'ASCII' (note: simply highlighting the 'PDG_Commerce' folder in the 'Local System' window of your FTP session and transferring the folder itself keeps all contents intact and creates a 'PDG_Commerce' subdirectory on the 'Remote System' side).

3. Resend any files as 'Binary' in the 'PDG_Commerce' directory that are marked as 'Binary' in chapter 5 (e.g., sslconx, blat.exe).

The 'PDG_Commerce' Directory

The contents of the 'PDG_Commerce' subdirectory are: four subdirectories: 'ProdText,' containing sample product text files; 'EmailTemplates,' containing default PDG Commerce Email templates; 'AdminTemplates,' containing the administration templates; and 'Intro,' containing the introduction pages. There are additional files in the 'PDG_Commerce' directory, such as ConfigPW, currency.txt, shipping.conf, .htaccess (UNIX), InvCount.txt, pdgzones.znf, state-list.txt, and shopper.conf.

The 'PDG_Commerce' folder for your PDG Commerce can be located either outside of your web site's document filesystem, inside the cgi-bin folder, or in the web site's document filesystem. Placing 'PDG_Commerce' outside of the document filesystem allows for additional security, since PDG Commerce's sensitive configuration and data files can be put in a location from where the web server will not serve documents. This location is specifically one folder up from the web site's document root. For example, if you ftp into your web site, and the folder you initially see contains an 'html' folder where all your documents are stored, you can place the 'PDG_Commerce' folder parallel to the 'html' folder.

When PDG Commerce executes, it will search for 'PDG_Commerce' in the following locations:

1. Outside of the web site's filesystem, specifically one folder up from the document root. **Note:** You may not have access to this folder. Please check with your hosting provider to see if you have the ability to locate files in this location.
2. Directly inside the web site's filesystem, specifically located directly in the document root.
3. Inside the cgi directory.

Transferring the 'Your_Document_Directory' Files

Continuing with your FTP session, transfer the contents of the 'Your_Document_Directory' subdirectory into your Web store's root document directory ('public-html' directory) in the following manner:

1. First, transfer the 'PDGCommTemplates' subdirectory and its contents. Subfolders of the 'PDGCommTemplates' directory contain skin files for use with PDG Commerce's new Site Design feature. The 'PDGCommTemplates' folder and its subdirectories contain image files, HTML template files, and text files. The graphics files, which end in '.gif', must be transferred in binary mode. The HTML files and the text files (ending in .txt or .conf) must be transferred in ASCII mode.
2. Second, transfer the 'CommConfig' subdirectory and its contents as "binary" (note: simply highlighting the 'CommConfig' folder in the 'Local System' window of your FTP session and transferring the folder

itself keeps all contents intact and creates a 'CommConfig' subdirectory on the 'Remote System' side).

The 'CommConfig' subdirectory contains all of the image files which appear on the Administrator's main menu, plus a few html, htm, js, and css files.

Retransfer these html, htm, js, and css files as ASCII.

3. Transfer the 'commerce.html' file as "ASCII"
4. For Microsoft Windows users that will be using Microsoft Access as their database, transfer the commerce.mdb file as "binary" to the PDG_Commerce directory in your cgi-bin directory.

At this point, all of the files necessary for PDG Commerce to function are now on your Web store's server. However, there is still some fine tuning left to be done.

Adjusting Files

If the cgi directory on your site is named something besides 'cgi-bin', you will need to make the following changes to your Commerce installation.

In the 'Local System' window of your FTP session,

1. Locate the 'commerce.html' file in the 'Your_Document_Directory' subdirectory and the 'index.html' file in the 'CommConfig' subdirectory in the 'Your_Document_Directory' subdirectory.
2. Highlight the 'index.html' file and click the 'View' button. This opens the file in Notepad.
3. Use the 'Find and Replace' option in Notepad to replace 'cgi-bin' with the correct directory name where the CommConfig program is located. Find the executables linked on the page and replace their extensions if you need. For Microsoft Windows servers, the extension will be ".exe". For UNIX systems, the extension may be ".cgi" or there may be no extension.
4. Save the changes and then re-upload the file, as 'ASCII', into the 'CommConfig' subdirectory in your Web store's root document directory.
5. In the 'Local System' window of your FTP session, locate the 'commerce.html' file and click the 'View' button.
6. Just as you made adjustments to the index.html file, make the same changes to this file, specifically correct the CGI directory as necessary. Save these changes and "re-transfer" the file as 'ASCII' into your Web store's root document directory.

If your CommConfig folder is not located in the root directory of your web site, you will need to make a change in the configuration of your PDG Commerce program. On your local machine, locate the "shopper.conf" file located in the "PDG_Commerce" folder inside the "Your_CGI_Directory" directory. Open this

file with a text editor. At the end of the file, add the “Config_Root=” variable and the corrected CommConfig path. For example:

```
Config_Root=/store/CommConfig/
```

Note: If you wish to access your Commerce Administrator securely, but the secure CommConfig is not accessed from the root of the web site, you will need to add a similar configuration variable to your shopper.conf file. For example, if your secure domain is `https://www.mysecuredomain.com/mywebstore/`, you would need to add the following to your shopper.conf:

```
Secure_Config_Root=/mywebstore/CommConfig/
```

Setting Permissions for 'PDG_Commerce' Subdirectory Contents

For Web server applications, there are two layers, or kinds, of permissions. There are file-level permissions and there are web server-level permissions. File level permissions indicate which user accounts on the server have access to which files. Web server level permissions indicate which directories and files the web server will allow users to browse or read with their browser.

For file level permissions, the ‘PDG_Commerce’ directory and its contents must have access to read and write its configuration files, and to create and delete temporary files. For Windows machines, this means ‘read’, ‘write’, ‘execute’, and ‘delete’ file permissions in place for the anonymous browser user. For UNIX machines, this means ‘read’, ‘write’, and ‘execute’ for whatever account that the web server uses when it runs a CGI program. Note that these are file permissions, NOT web server permissions.

Web server permissions MUST be set to prevent reading and browsing of your ‘PDG_Commerce’ directory. For Windows servers, this means that ‘read’, ‘write’, and ‘browse’ are to be turned off. For UNIX servers, this permissions can be set with htaccess files or with the web server configuration. Note that these are web server permissions, NOT file permissions.

NOTE THAT WEB SERVER PERMISSIONS ARE SET IN THE WEB SERVER CONFIGURATION - NOT BY WINDOWS EXPLORER OR BY CHMOD.

WHEN PERMISSIONS ARE SET CORRECTLY, YOUR PDG COMMERCE WILL OPERATE PROPERLY AND CUSTOMERS WILL NOT BE ABLE TO BROWSE YOUR DATA FILES.

If your ISP or site's host does not have a way for you to set these yourself, you should contact them for assistance in setting these permissions.

See Chapter 6 of this guide for details on setting permissions!

Install the PDG Commerce License

PDG Commerce in general will obtain and install its license automatically from PDG Software.

In the case that the automated licensing does not work properly, PDG Software may send you a license file to upload on request. Open this e-mail message. Copy the three lines of license information by highlighting the text and clicking the copy button on the toolbar.

The license text looks like this:

```
yourwebstore.com  
ABCDEFGHIJKLMNPOQRSTUVWXYZAABBCC  
0!pdg@pdgsoft.com
```

Create a text file named 'shopper.lic' and open it with notepad. Paste the license text into the file and save it. Transfer the file as 'ASCII' into the 'PDG_Commerce' directory of your Web store.

Your PDG Commerce has been installed. Remember, if you created an alternative "images" directory, you need to adjust the URL of product images within the Administrator.

You can test your installation of PDG Commerce by pointing your browser to:

[www.\[insert Web store domain here\].com/commerce.html](http://www.[insert Web store domain here].com/commerce.html)

Local Installation

It is possible to install PDG Commerce on a local PC. However, if you are installing locally, your computer must meet the system requirements stated at the beginning of this manual and you must configure database connectivity for local access instead of on the host's web server.

Local installation is similar to web server installation, except that you copy files, not FTP, to your wwwroot directory.

After downloading and unzipping the archive, copy the PDG Commerce files to their appropriate folders in your local wwwroot directory. These locations are described in the section on Web Server Installation. Note that you must also set permissions for these files just as you would on the host server.

See Chapter 6 of this guide for details on setting permissions!

Note: If you are utilizing the 30 day trial on your local machine, you will need to contact PDG Software to obtain your license as your testing web site may not be able to connect to the PDG Software license database through the World Wide Web.

However, if testing locally, you must use a personal web server and access your PDG Commerce through a web browser.

After copying the files locally, you must configure database connectivity for local access.

Database Setup

To setup the PDG Commerce database connection, first make sure your web server is running. Open your web browser and in the address bar type, “http://[site name]/commerce.html” - where [site name] is the website name (or local machine name if you are setting up the database locally).

Click the “Enter the administrator” link.

Enter the default password (LETMEIN) and click on the “Login” button or simply press <Enter>. When the licensing agreement screen pops up, simply press the “I Agree” button.

Click on the Database Options link.

If the Database Options are not set up or are misconfigured, selecting any other option will result in the Database Options screen being displayed.

Here is where you set your database connection.

Database Driver Type

Select the appropriate database driver type from the pulldown list. If you are using the default database provided with PDG Commerce, accept the default Microsoft Access Driver. Otherwise, select the database driver that matches the brand of database you are using.

DSN

This is the name of the data source file, which will contain the complete database for your Web site. This field is required unless you are using the default Microsoft Access database. Otherwise you will need to configure a Data Source Name on the webserver, and then enter the DSN here.

SQL Server

This field is used to specify the name of the SQL server you are connecting to if you are using a SQL database. If you are not using SQL server, leave this field blank.

SQL Server Database

This field is used to specify the name of the SQL database if you are using a SQL database. If you are not using a SQL database, leave this field blank.

MS Access database filename

This field is used to specify the name of the MS Access database. The default is “commerce.mdb”. If you are using a different MS Access database, enter its name here. Any path information provided with the filename is relative to the “PDG_Commerce” directory.

Login Name

This field is used to specify your SQL login name. If you are not logging into a SQL database, leave this field blank.

Password

This field is used to specify your SQL password. If you are not logging into a SQL database, leave this field blank.

Setting Up the Database

After entering your database connectivity information, click the ‘Submit Changes’ button. If the information was all entered correctly, a button will now appear at the top of the page called ‘Install the Commerce Database (version 2.25)’. Click this button to install the appropriate PDG Commerce tables into your database.

Logging In to the Commerce Administrator

When you are ready to log in to your Commerce Administrator, you may access the log in page from the “Administration” link on the commerce.html page. As noted on this page, your default login will be Admin with a password of LET-MEIN.



You should now begin creating your web store, by putting calls to PDG Commerce in your site. These calls can either be HTML hyperlinks or forms. Complete details on this are in the **PDG Commerce Technical Reference**.

You can always see examples of these calls in the provided 'commerce.html.'

PDG Software also has plugin components available for Macromedia Dreamweaver, Microsoft Frontpage, and NetObjects Fusion. These plugins automate the process of embedding Commerce functionality in your web site without writing code.

You may download any component and its installation guide from the PDG Software website at, <http://www.pdgsoft.com>.



The following page illustrates the directory file structure of a fully installed version of PDG Commerce.

The file permissions shown are UNIX based. They are equivalent to the following file level permissions for Windows:

- **rwX** : Read, Write, Execute, Delete
- **r-x** : Read, Execute
- **r--** : Read

In setting these file-level permissions for UNIX systems, first try setting the specified permissions for “User” only, and setting “Group” and “Other” to 0. Then test PDG Commerce by placing an order, or making a change to a shopping cart option in the Merchant Administrator. If PDG Commerce cannot create the temporary files, then try setting the permissions for “User” and “Group” and test again. Finally if that does not work, try setting the permissions for “User,” “Group,” and “Other.”

In setting these file-level permissions for Windows systems, check with the web server to see what account is used for anonymous browsing. Then set the proper permissions for the files for that account.

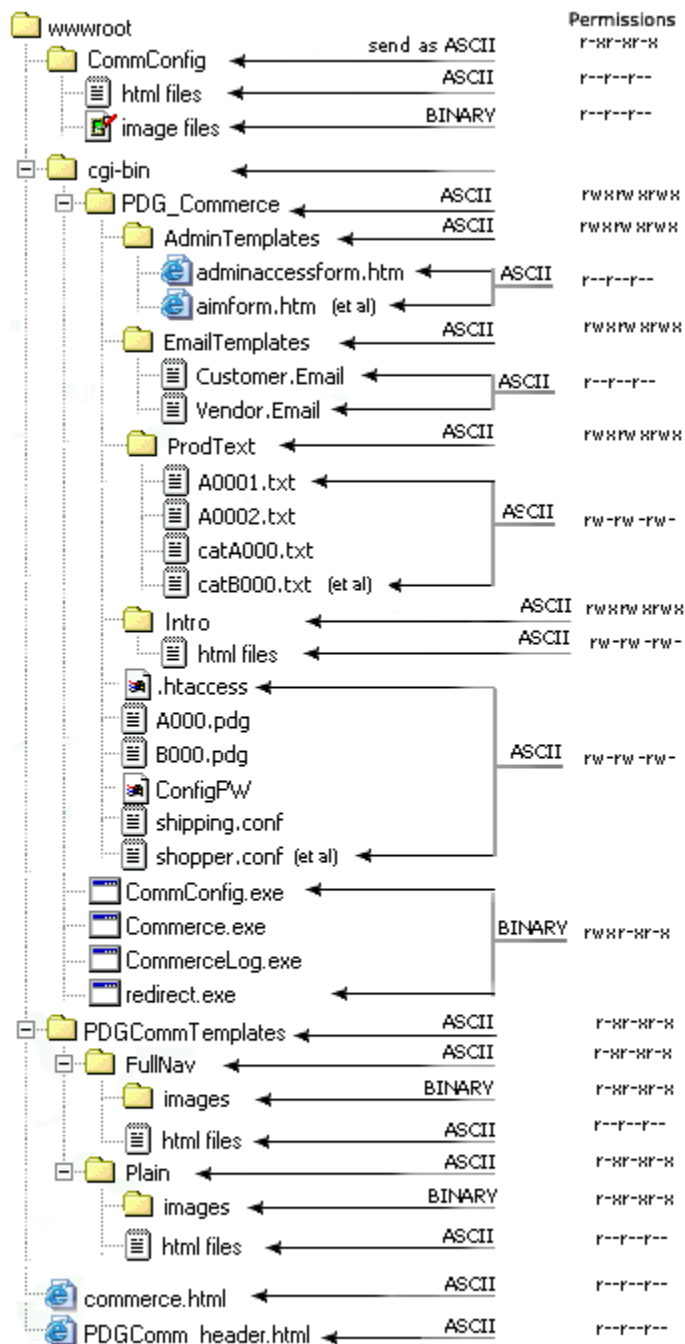

Complete PDG Commerce File Structure



The contents of the “PDG_Commerce” directory must have both file and web server level permission set correctly to operate.

For Windows machines, the “PDG_Commerce” directory must have “Read” “Write” and “Delete” file level permissions set for the anonymous browser account. If your ISP or site’s host does not have a way for you to set these yourself, you should contact them for assistance and provide them with the following settings information.

Windows NT Permissions

If you are setting the permissions yourself, follow the steps below. Note that you will have to set different permissions for different directory folders and files.

File level permissions

Right click on the 'My Computer' icon and select 'Explore.' This action will open Windows Explorer. Locate the 'Inetpub' folder, then the 'wwwroot' folder in its subdirectory.

Clicking on the 'wwwroot' folder, locate the 'cgi-bin' folder and select 'properties', then the 'security' tab, then press the permissions button - as illustrated in the graphic below.

You will need to set the permissions in each directory by right clicking on the cgi-bin, PDG_Commerce, CommConfig, and PDGCommTemplates folders and selecting 'properties'

<i>Select 'Properties' on folder...</i>	<i>Permissions</i>	<i>Check 'Replace Permissions On'</i>
cgi-bin	Read (RX)(RX)	Yes
PDG_Commerce	Full Control (All)(All)	Yes
CommConfig	Read (RX)(RX)	Yes
PDGComm Templates	Read (RX)(RX)	Yes

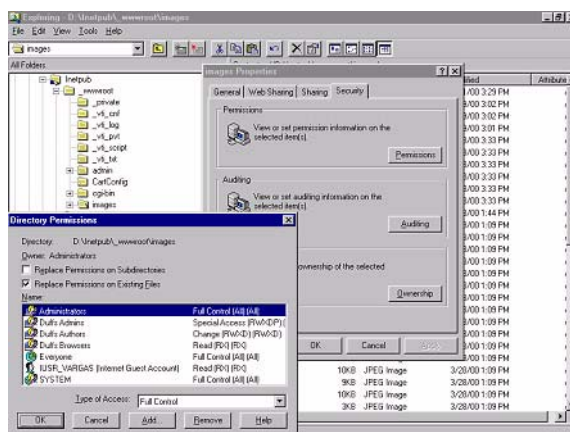

Web Server level permissions

The next chart illustrates how the properties should be set on the Windows NT version of PDG Software.

First of all, select the 'Programs' field on your Windows menu bar. Then select 'Windows NT 4.0 Option Pack' (or the option corresponding to the current version you are running), then 'Microsoft Internet Information Server', then 'Internet Service Manager.' These actions will bring up the Management Console.

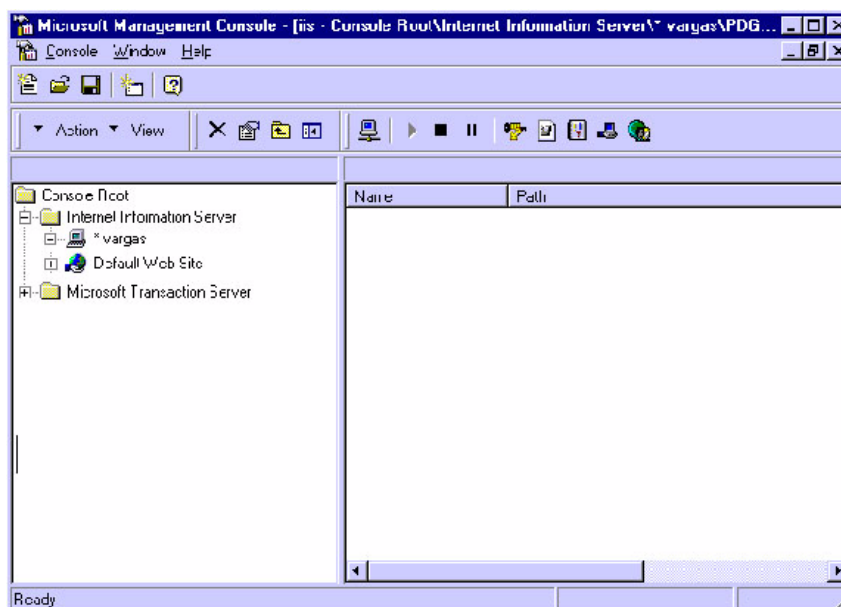

Locate your website folder in the Management Console.

Locate each of the folders specified in the chart below, beginning with the 'cgi-bin' folder. Please take note of the following four points:

- The server level permissions are set by right clicking the 'Properties' section of each respective folder. These settings are made in the 'Directory' section.
- Specifically, the 'Read,' 'Write' and 'Log Access' settings are made in the 'Access Permissions' section and the 'Execute' setting is made in the 'Permissions' section.
- A 'X' in the chart indicates that the permission should be set, a blank field indicates that the permission should not be checked.
- Be sure to click 'Apply' then 'OK' to implement the correct settings

<i>Folder</i>	<i>Read</i>	<i>Write</i>	<i>Execute</i>	<i>Log Access</i>
cgi-bin			X	X
PDG_Commerce			None	Optional
CommConfig	X		None	Optional

Windows 2000 Permissions

If you are setting the permissions yourself, follow the steps below. Note that you will have to set different permissions for different directory folders and files.

File level permissions

Right click on the 'My Computer' icon (or go to your host root directory) and select 'Explore.' This action will open Windows Explorer. Locate the 'inetpub' folder, then the 'wwwroot' folder in its subdirectory.

Click on the 'wwwroot' folder and locate the 'cgi-bin' folder. Right click on it and select 'properties.' Click the 'Security' tab.

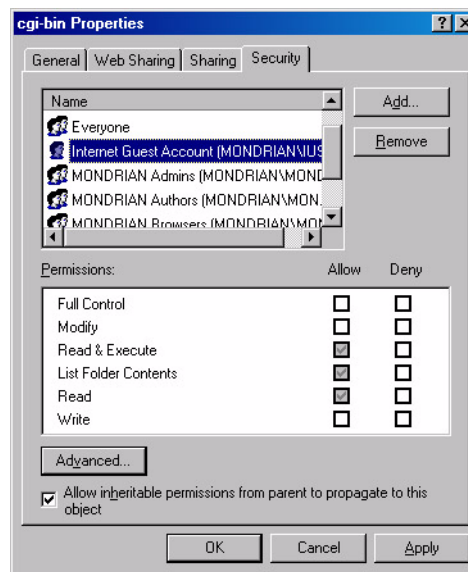

Use this dialog box to set permissions for the anonymous browser account according to the following chart.

<i>Select 'Properties' on folder...</i>	<i>Permissions</i>
cgi-bin	Read & Execute
PDG_Commerce	Modify
CommConfig	Read & Execute
images	Read & Execute
PDGCommTemplates	Read

Enable "Apply these permissions to object and/or containers within this container only" by placing a check in the checkbox.

Click on the "OK" button.

Web Server level permissions

To set the appropriate IIS settings, follow the steps below.

From your desktop, click on Start -> Programs -> Administrative Tools -> Internet Service Manager.

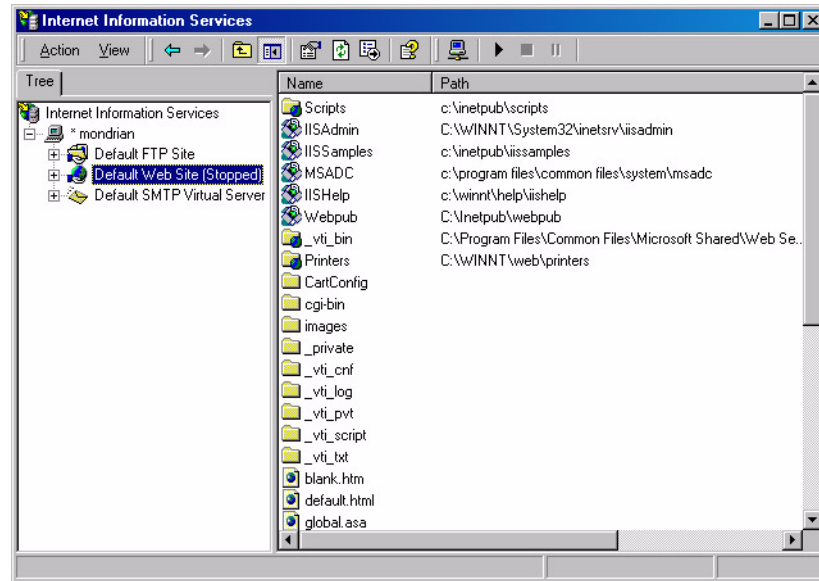

Locate the folder on the left side for the web server with which you are working (expand the listing as necessary by clicking the plus signs). Right click on the folder and select properties.

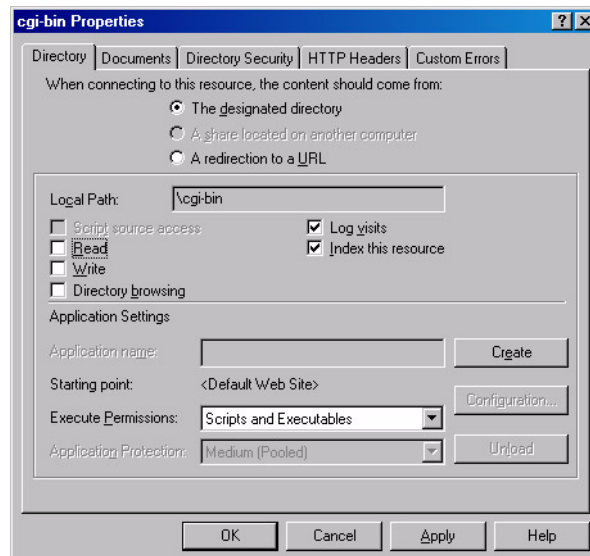

To set Read, Write, or Log Access, use the checkboxes next to the appropriate settings. To set or unset Execute, use the pull-down menu next to 'Execute Permissions.'

<i>Folder</i>	<i>Read</i>	<i>Write</i>	<i>Execute</i>	<i>Log Access</i>
cgi-bin			X	X
PDG_Commerce			None	Optional
CommConfig	X		None	Optional

Unix Permissions

If you are setting the permissions yourself, follow the steps below. Note that you will have to set different permissions for different directory folders and files.

File level permissions

You will need to use ‘CHMOD’ to set file-level permissions for your files. UNIX has three types of file level permissions: “User,” “Group,” and “Other.” Using your FTP client, issue CHMOD commands to set directories and files according to the permissions listed in the figures in chapter 5. You first want to set these for just “User,” while turning off permissions for “Group” and “Other.” Test this by entering your Merchant Administrator and make a change to the ‘Shopping Cart Settings.’ Now exit your Merchant Administrator and relog in and see if the setting saved. If it hasn’t, try setting the permissions listed in the figures in chapter 5 for both “User” and “Group.” Then test again. If that fails, try setting the permissions for all three types and test.

Server level permissions

For most all UNIX servers, server level permissions can be set with “.htaccess” files. These are ASCII text files that can be placed in a directory. When the web server receives a request for a document in that directory, it checks for an htaccess file and verifies access.

PDG Commerce comes with an htaccess file that blocks all browser requests. Place this “.htaccess” file (using ASCII upload) into your PDG_Commerce folder. This should block out browse attempts to your data. If it does not, you may need to check your web server configuration or with your hosting company. If you do consult your hosting company, be sure that they understand that these server level permissions are configured with htaccess-type files or with the web server itself. Web server permissions CANNOT be set on the file level with CHMOD or with file-ownership.

